

COMP-5/7.5/10

ECS Air Compressor



Features

Aftercooler included (COMP-7.5/10 only)

Low Oil Level Sensor - Automatically shuts down compressor (COMP-7.5/10 only)

½" NPT Female Outlet (COMP-5/7.5/10)

1" NPT Female Outlet (COMP-10)

Automatic condensate drain – ¼" NPT Female

General Description

The ECS Air Compressors are paired with the ECS Protector Nitrogen Generators in facilitating the **Dry Pipe Nitrogen Inerting (DPNI)** process in dry pipe and preaction fire sprinkler systems. COMP-7.5/10 when paired with the AG-18500/22500 nitrogen generators can be used as a plant nitrogen source in facilitating the **Wet Pipe Nitrogen Inerting (WPNI)** process in wet pipe sprinkler systems.

Specifications

Cabinet Dimensions COMP-5 COMP-7.5 COMP-10	32" (L) x 20" (W) x 70" (H) 38.1" (L) x 23.6" (W) x 70.1" (H) 30" (L) x 43.2" (W) x 76.6" (H)
Weight	COMP-5 (435 Lbs), COMP-7.5 (573 Lbs), COMP-10 (800 Lbs)
Power Supply Compressor	480VAC/3 phase/60Hz (Standard) 208VAC/3 phase/60Hz (Optional)
Power Supply Auto Drain	120VAC/1 phase/60Hz (can be connected to the nitrogen generator cabinet power supply)
Air Connection	COMP-5/7.5 (½" NPT Female) COMP-10 (1" NPT Female)
Drain Connection	¼" NPT Female
Temperature Range	40°F - 105°F (5°C - 40°C)

Maintenance

Refer to Manufacturer's recommended maintenance in Ingersoll Rand owner's manual

Operating Performance

Model Number	COMP-5	COMP-7.5	COMP-10
Air Supply SCFM (L/min)	14.3 (405)	24 (680)	35 (992)
Single System Capacity† @ 40 psig (2.8 bar) Gallons (Liters)	1,150 (4,353)	2,025 (7,665)	2,900 (10,978)
Single System Capacity† @ 20 psig (1.4 bar) Gallons (Liters)	2,300 (8,706)	4,050 (15,331)	5,800 (21,955)

† Capacity based on NFPA 13 30-minute fill requirement of largest single system

Power Requirements

Model Number	COMP-5	COMP-7.5	COMP-10
208VAC/3 Phase	17.5 Amps	25.3 Amps	32.2 Amps
480VAC/3 Phase	7.6 Amps	11 Amps	14 Amps

Installation

The air compressors are designed to be mounted directly to the floor in the fire sprinkler riser room. Vibration pads (supplied) must be installed under the feet of the air compressor to ensure warranty of the air compressor. Allow access to the power supply (one (1) dedicated circuit), access to the nitrogen generator inlet ½" supply line and access to a drain for the condensate discharge line. Allow for clearance to access air compressor for servicing. For detailed installation and operation please refer to the ECS AdvancedIQ Nitrogen Generator Manual.

COMP-5/7.5/10

ECS Air Compressor

COMP-5

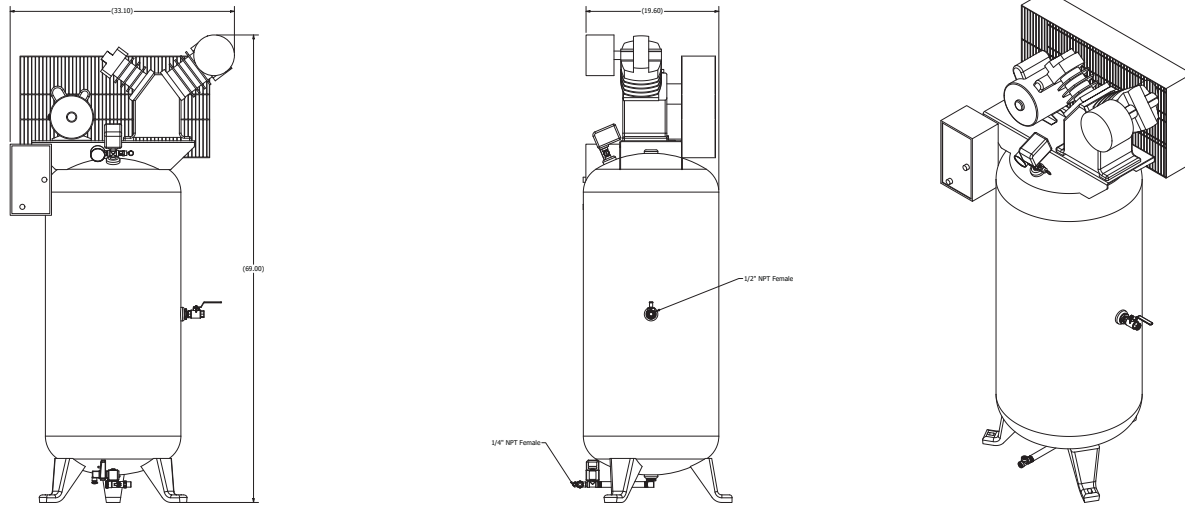

COMP-7.5

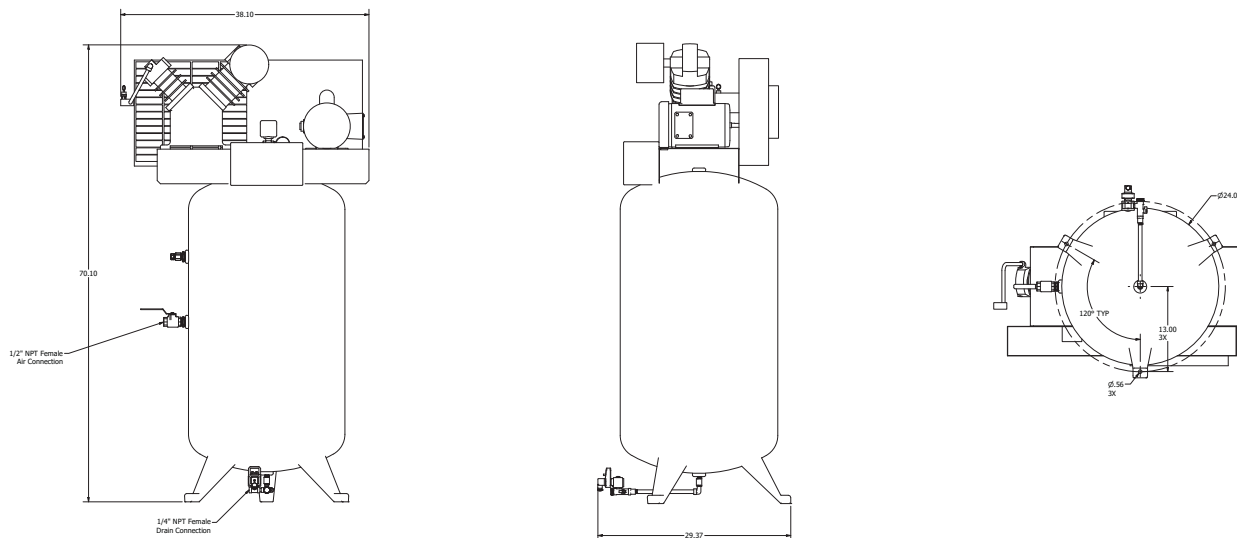

COMP-10

